

Gateway Installation Instructions

PREPARATION

Unpack and inspect all materials to ensure they are free from damage. Check to make sure that all the components and tools are available.

Unroll/unpack the sections of matting and lay in a clean dry protected area to allow the mats to acclimatize and relax. Depending on the duration of storage and the ambient temperature, this could take up to 24 hours.

When handling the mats at any time during the installation, take care to avoid dragging or rough handling that could stretch or distort them.

REQUIRED MATERIALS

Gateway matting
Perimeter J Frame (if specified)
Mat Divider (if specified)
Ramp (if specified)
Tapcons, M12 ¼" x 1 ¾" (not supplied) or/
Screws & Plugs ¼" x 1 ¾" (not supplied).
Spikes (not supplied)

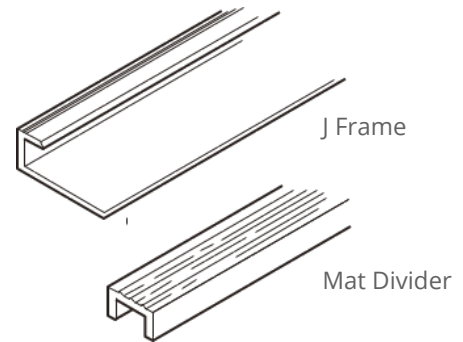

Note: Mat Dividers can be used as a perimeter frame if desired

EQUIPMENT REQUIRED

Mitre Saw	48" T Square
Hammer Drill	Straight Edge
Robertson #12 Bit	Utility Knife
1/4" Masonry Bit	Scraper
Hammer	Countersink

THE RECESSED WELL PREPARATION

The recessed well should be formed to a depth to accommodate the J Frame.
The 14mm J Frame requires a minimum of 19mm recess.
The 10mm J Frame requires a minimum of 16mm recess.
Both should have a level and sound base free from any obstructions.

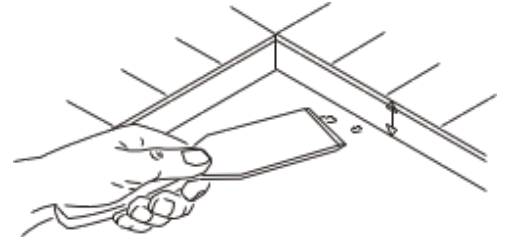

Before starting the installation, visually check the recess. Using a scraper, remove any lumps or ridges in the well base. Vacuum or sweep the recess before installing the mat.

INSTALLING THE J FRAME

The J Frame is designed to cap the mat on all 4 sides. All 4 corners of the frame must be neatly mitered. Mark, drill and countersink the holes in the frame.
Minimum 2" from the corners and 12"4 along the lengths.

Set the Frame in place, mark the location of pre-drilled holes on the well base. Using a 1/4" masonry bit drill the holes to accept the plugs.

Clear the dust from the freshly drilled hole and tap in the plug.

Mechanically, secure the frame.

Repeat this process for the installation of the mat dividers (if required) which should be cut to size on site.

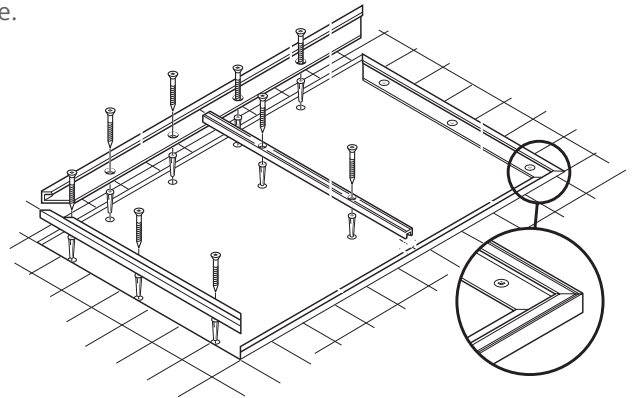

Tip: It is easier to position the mat dividers up against each individual section of matting and secure, rather than installing the mat dividers first and cutting the mat to fit. Once again ensure the well is free of debris.

MEASURING THE INSIDE DIMENSION

Inside Dimension refers to the measurement to the inside of the frame.
Before cutting the mat, take the inside dimension, both length and width.

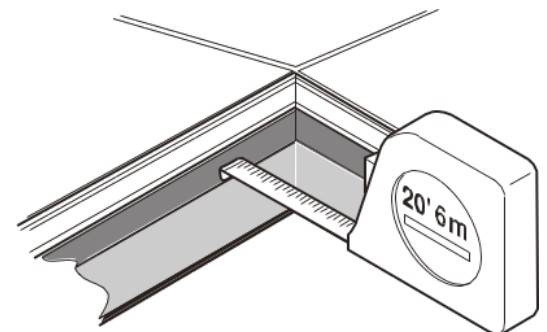

CUTTING THE MAT

With the mat on a smooth level surface, cut one end, using the "T" Square as a guide. Do not concern yourself if the cut you have made passes through a bottom rib. Do not use the bottom rib as your guide!

Transfer the inside frame dimension to the mat and make your second cut. Take particular care to keep the blade pressure light. Too much pressure can cause the blade to skate or break. Make several light passes to ensure a clean cut.

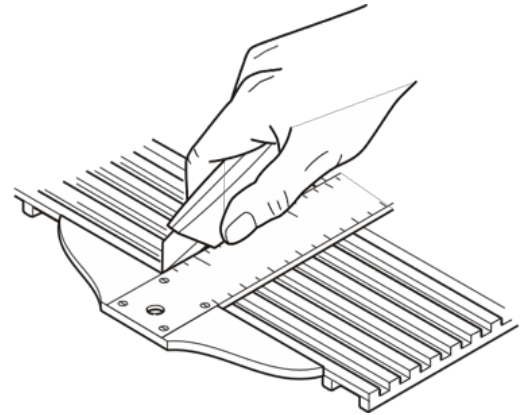

FITTING THE MAT

Gateway is flexible.

Slide one end of the mat under the J Frame cap, flex the mat, repeat on the opposite side. Continue with other mat sections, if applicable, until the recess is filled. Irregular shapes whether angles or radius can be trimmed on site.

Should you need to remove mat sections, use a straight blade screwdriver or similar positioned between the top ribs and flex the mat enough to allow removal by hand.

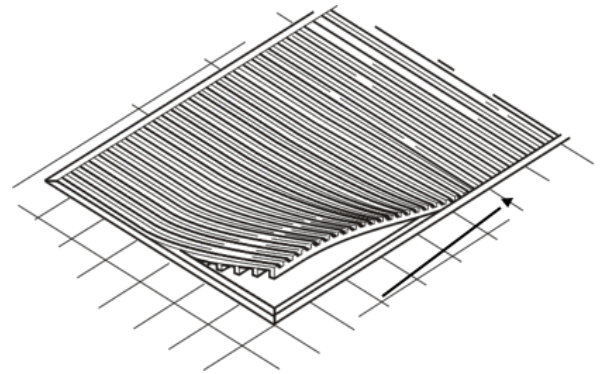

TIPS AND TRICKS

PROTECTING THE FRAME ON SITE

To ensure the mat retains a like new appearance, install the mat just prior to the final inspection.

Protect the frame from damage by installing plywood in the recess to the appropriate height. Consider strips of plywood inserted under the lip of the frame and then cut and fit the remaining area to protect the frame from crushing by other trades on site.

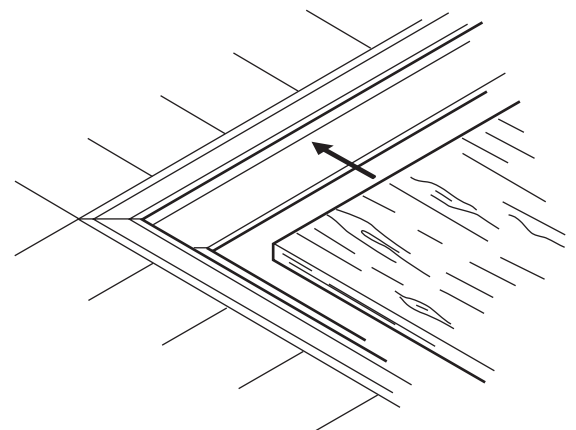

RELAXING THE MAT WITH HEAT

For the ease of transportation the mats are shipped in a roll.

Before you cut the mat, you need to allow it to relax on a flat surface.

To accelerate this process, use a hot air gun to warm air through the mat. Directing the hot air from as far back as 10" from the end of the mat will allow the ends to fall flat. Move the heat around.

Do not leave the heat unattended or in one spot.

Do not cut the mat until it has had a chance to cool.

We are here to help. Call us for technical assistance; 1-866-819-6825

